

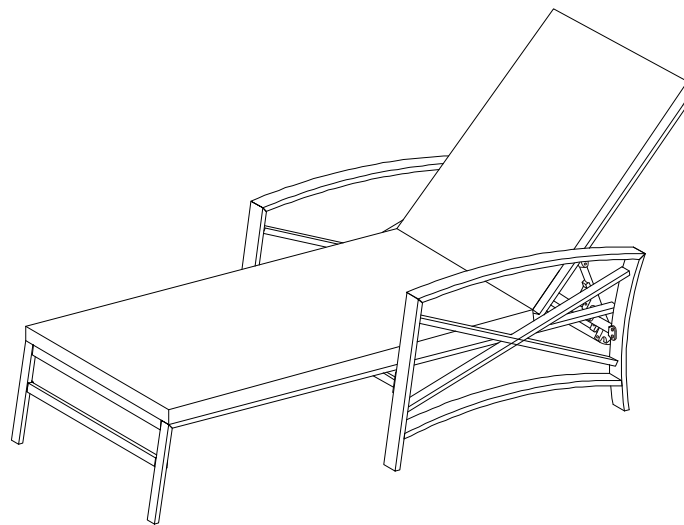

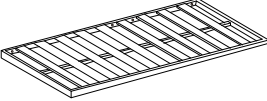

Outdoor Lounge Chair
CO6212

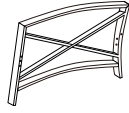
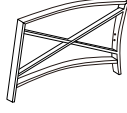
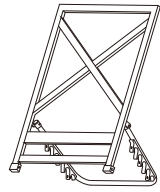
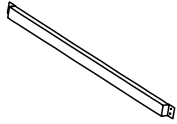
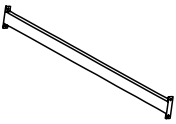
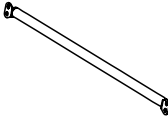
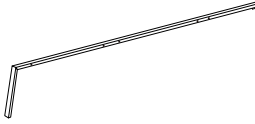
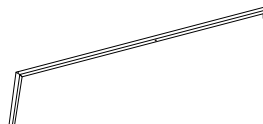
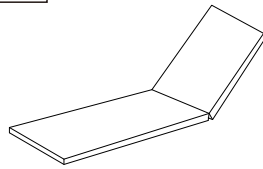
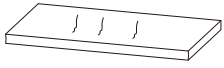
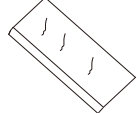

PART LIST

<p>A</p> 	<p>B</p> 	<p>C</p> 	<p>D</p> 	<p>E</p> 
<p>Seat Panel 1 PC</p>	<p>Left Arm Panel 1 PC</p>	<p>Right Arm Panel 1 PC</p>	<p>Backrest Panel 1 PC</p>	<p>Front Bar 1 PC</p>
<p>F</p> 	<p>G</p> 	<p>H</p> 	<p>I</p> 	<p>J</p> 
<p>Medium Bar 1 PC</p>	<p>Backrest Bar 1 PC</p>	<p>Left Pipe 1 PC</p>	<p>Right Pipe 1 PC</p>	<p>Cover of Cushion * 1 PC</p>
<p>K</p> 	<p>L</p> 	<p>*Please note cushion covers will ship separately.</p>		
<p>Core of Seat Cushion 1 PC</p>	<p>Core of Back Cushion 1 PC</p>			

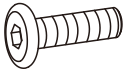
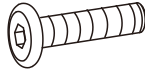
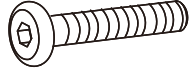
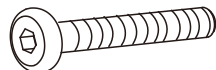
HARDWARE LIST

<p>#1</p>  <p>M6*15mm</p>	<p>#2</p>  <p>M6*25mm</p>	<p>#3</p>  <p>M6*42mm</p>	<p>#4</p>  <p>M6*55mm</p>	<p>#5</p>  <p>M6mm</p>
<p>Short Bolt 14 PCS (Extra 1)</p>	<p>Medium Bolt 6 PCS (Extra 1)</p>	<p>Long Bolt 2 PCS (Extra 1)</p>	<p>Longest Bolt 2 PCS (Extra 1)</p>	<p>Flat Washer 24 PCS (Extra 1)</p>
<p>#6</p>  <p>M6mm</p>				
<p>Allen Wrench 1 PC</p>				

Step 1. Attach seat panel (part A) to left pipe (part H) and right pipe (part I) using medium bolts (part #2), flat washers (part #5) and allen wrench (part #6).

NOTE: Please do not fully tighten bolts until unit is fully assembled.

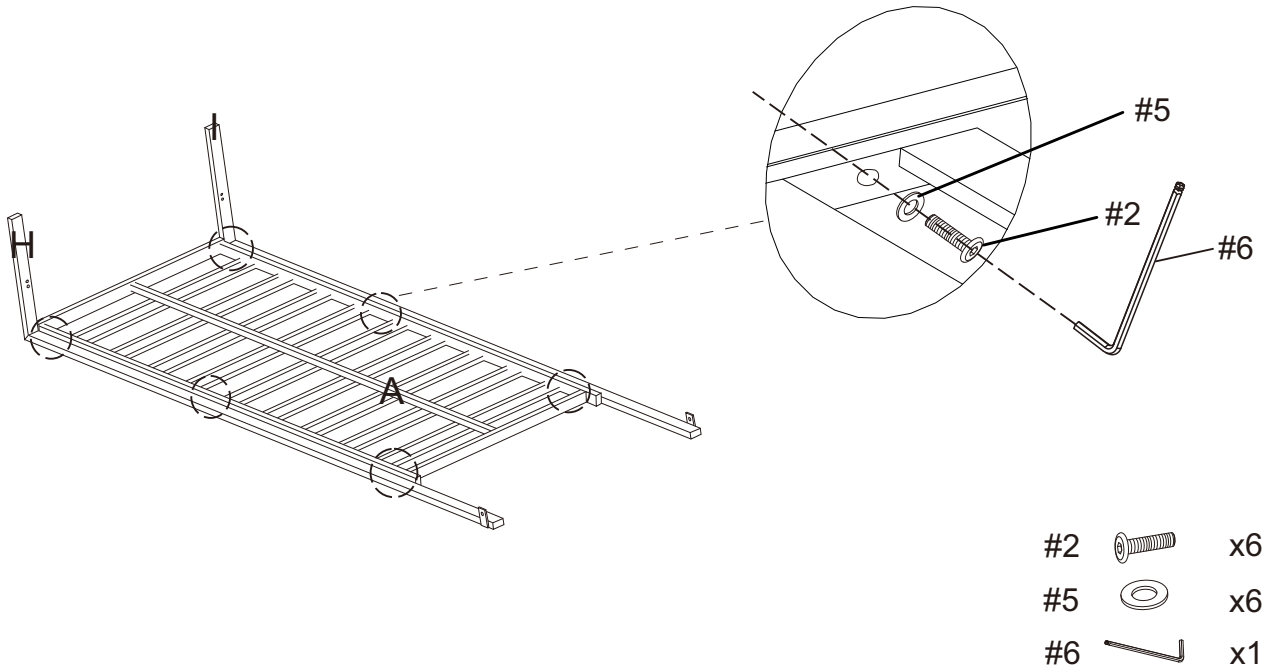

Step 2. Attach front bar (part E) to left pipe (part H) and right pipe (part I) using short bolts (part #1), flat washers (part #5) and allen wrench (part #6).

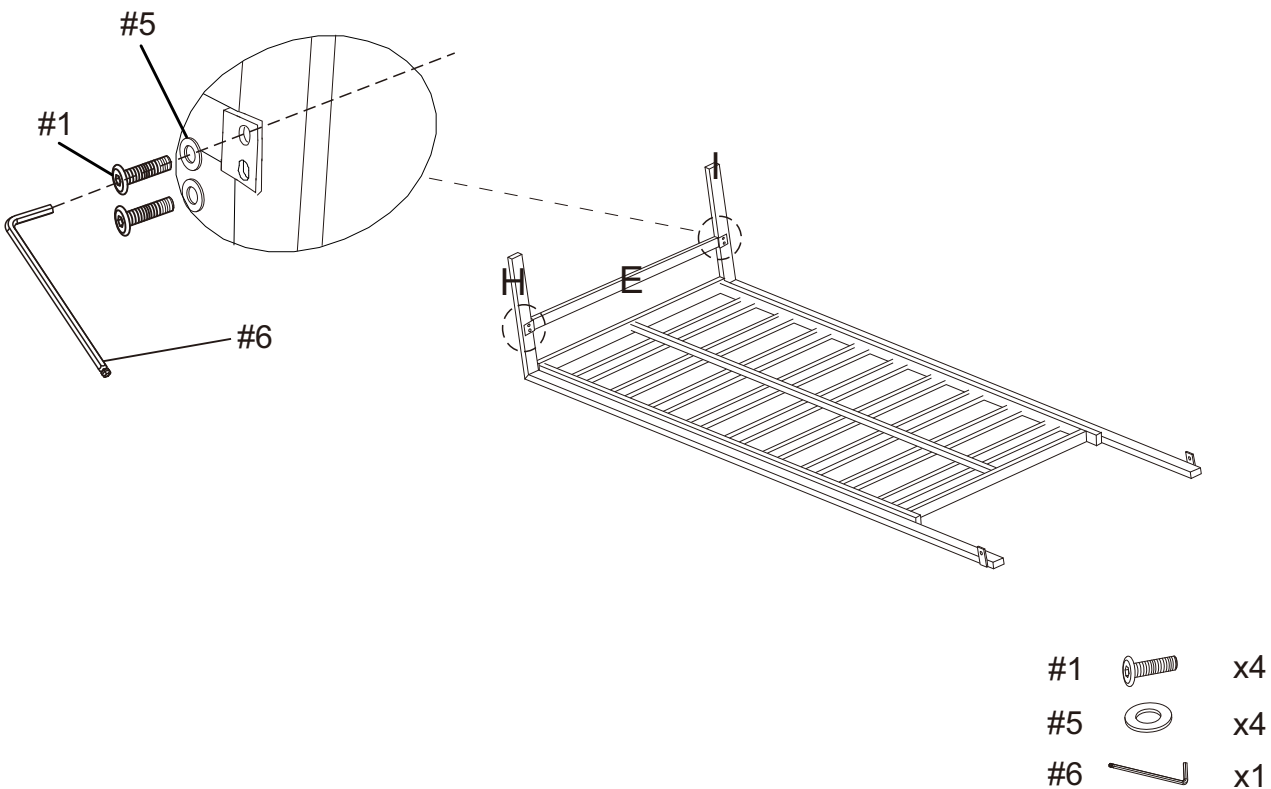

NOTE: Please do not fully tighten bolts until unit is fully assembled.

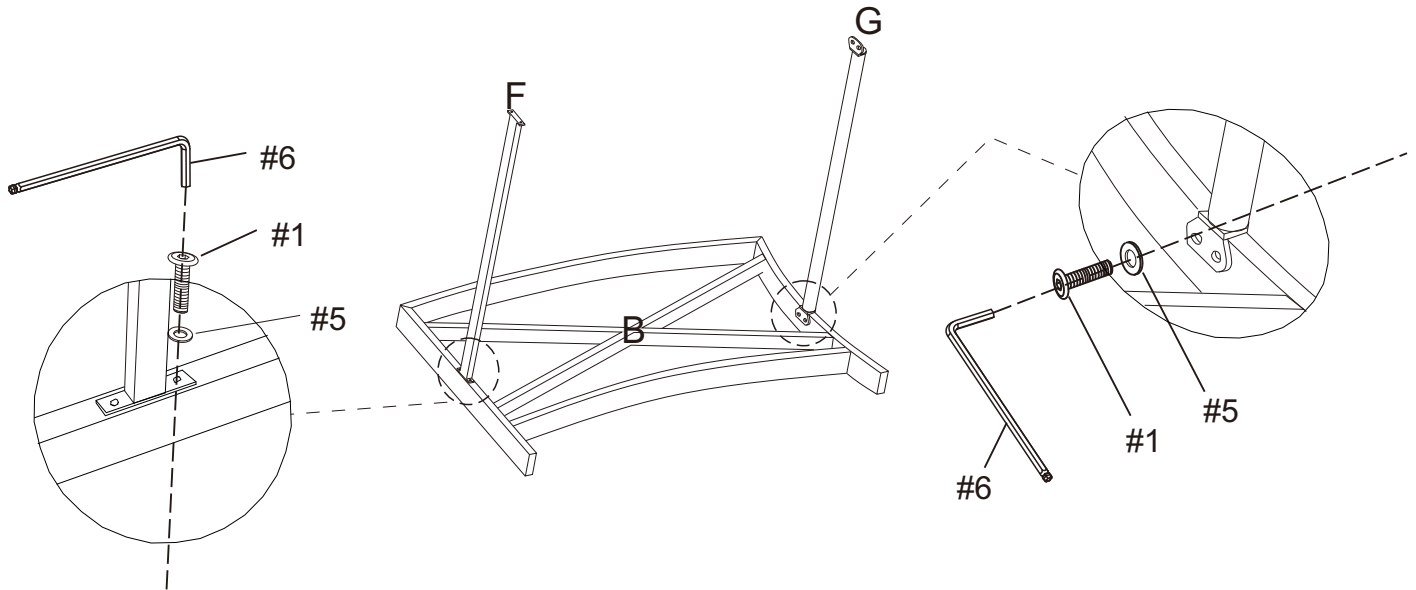

Step 3. Lay left arm panel (part B) upside down on a soft flat surface, such as carpet, as shown below. Attach medium bar (part F) and backrest bar (part G) to left arm panel (part B) using short bolts (part #1), flat washers (part #5) and allen wrench (part #6).

NOTE: Please do not fully tighten bolts until unit is fully assembled.





- | | | |
|----|---|----|
| #1 |  | x4 |
| #5 |  | x4 |
| #6 |  | x1 |

Step 4. Attach right arm panel (part C) to medium bar (part F) and backrest bar (part G) using short bolts (part #1), flat washers (part #5) and allen wrench (part #6).

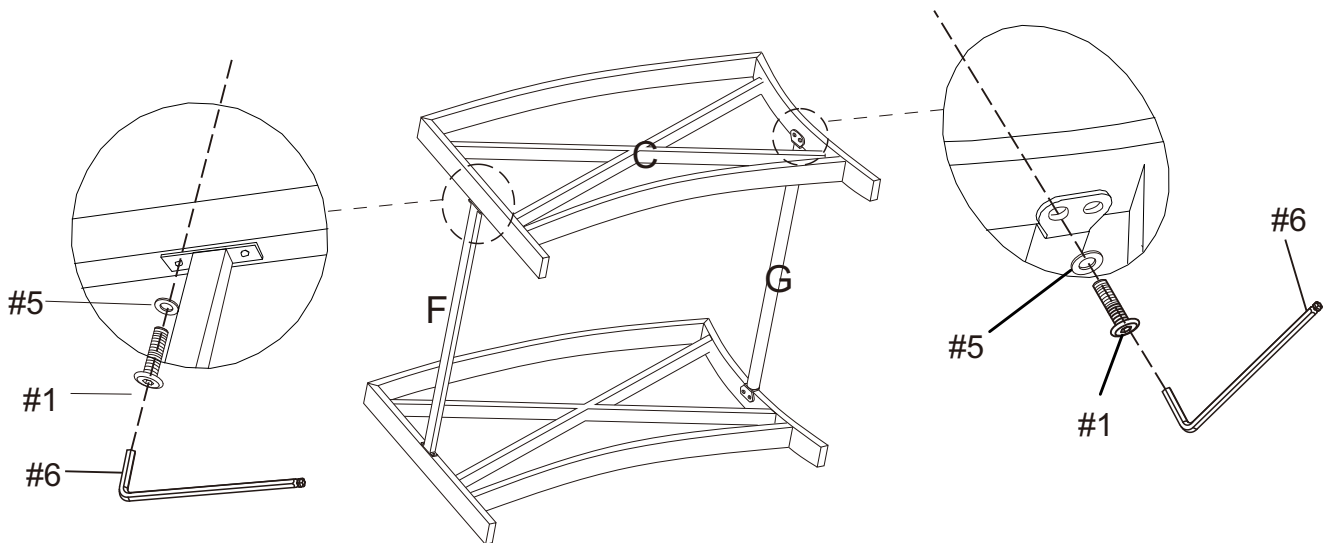
NOTE: Please do not fully tighten bolts until unit is fully assembled.



- | | | |
|----|---|----|
| #1 |  | x4 |
| #5 |  | x4 |
| #6 |  | x1 |

Step 5. Attach assembled unit (parts A, H & I) to left arm panel (part B) and right arm panel (part C) using short bolts (part #1), longest bolts (part #4), flat washers (part #5) and allen wrench (part #6).

NOTE: Please do not fully tighten bolts until unit is fully assembled.

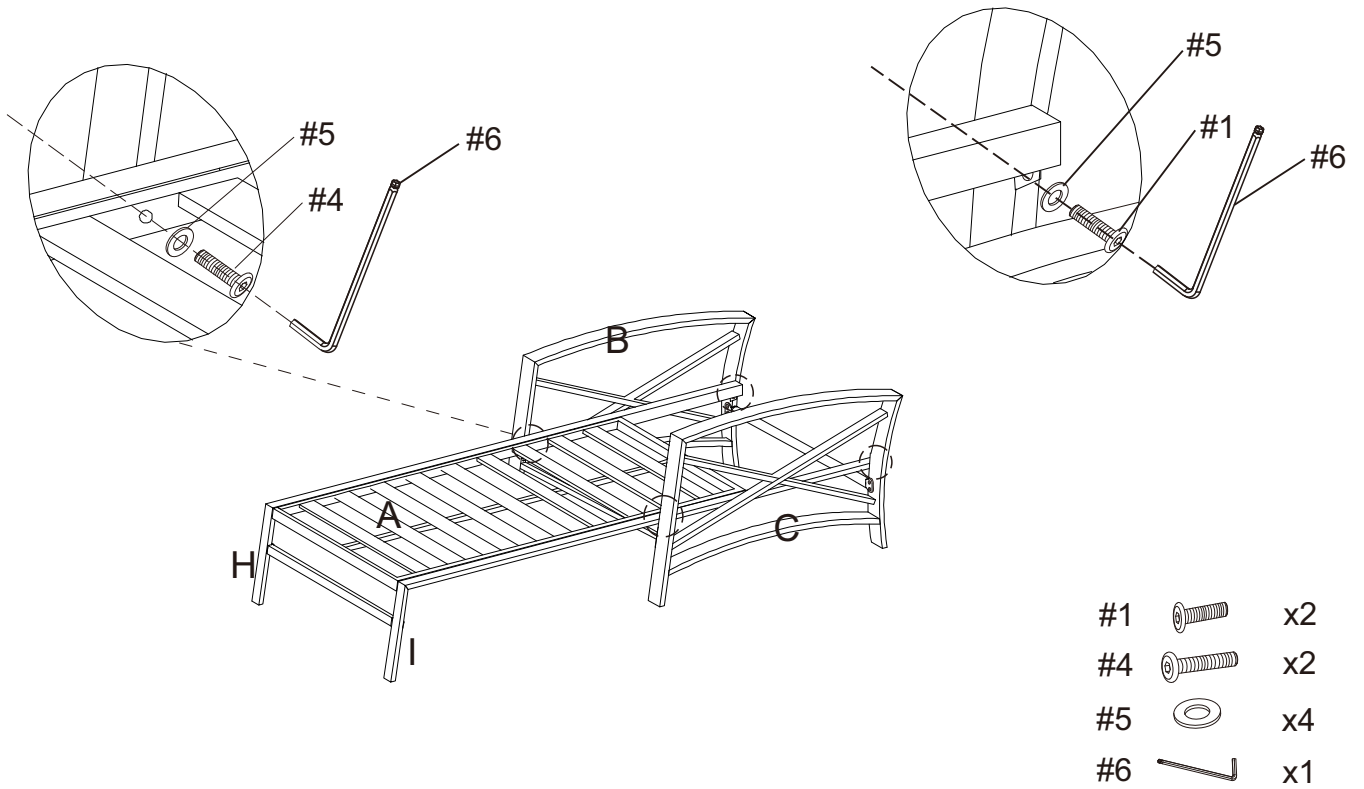

Step 6. Attach backrest panel (part D) to assembled unit (parts H & I) using long bolts (part #3), flat washers (part #5) and allen wrench (part #6).

NOTE: Please fully tighten all bolts at this time.

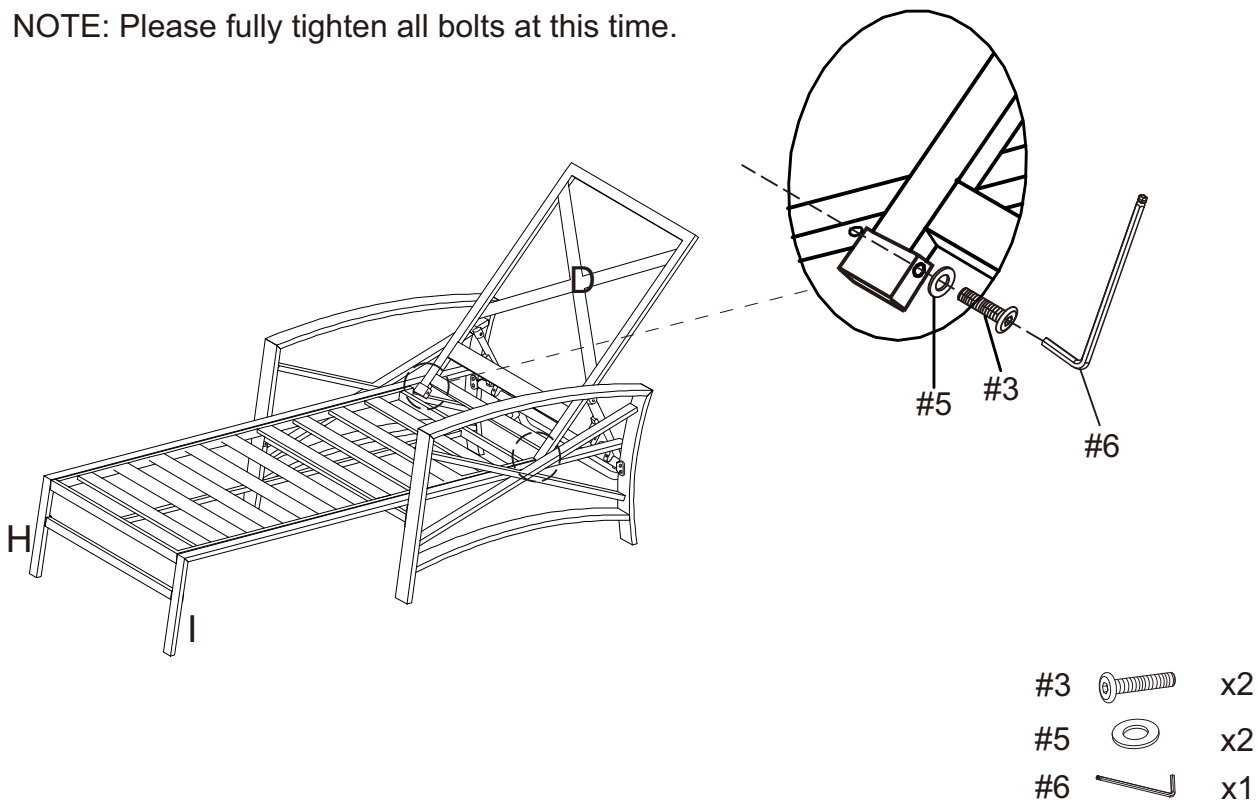

Step 7. Insert core of seat cushion (part K) into cover of cushion (part J).
Insert core of back cushion (part L) into cover of cushion (part J).

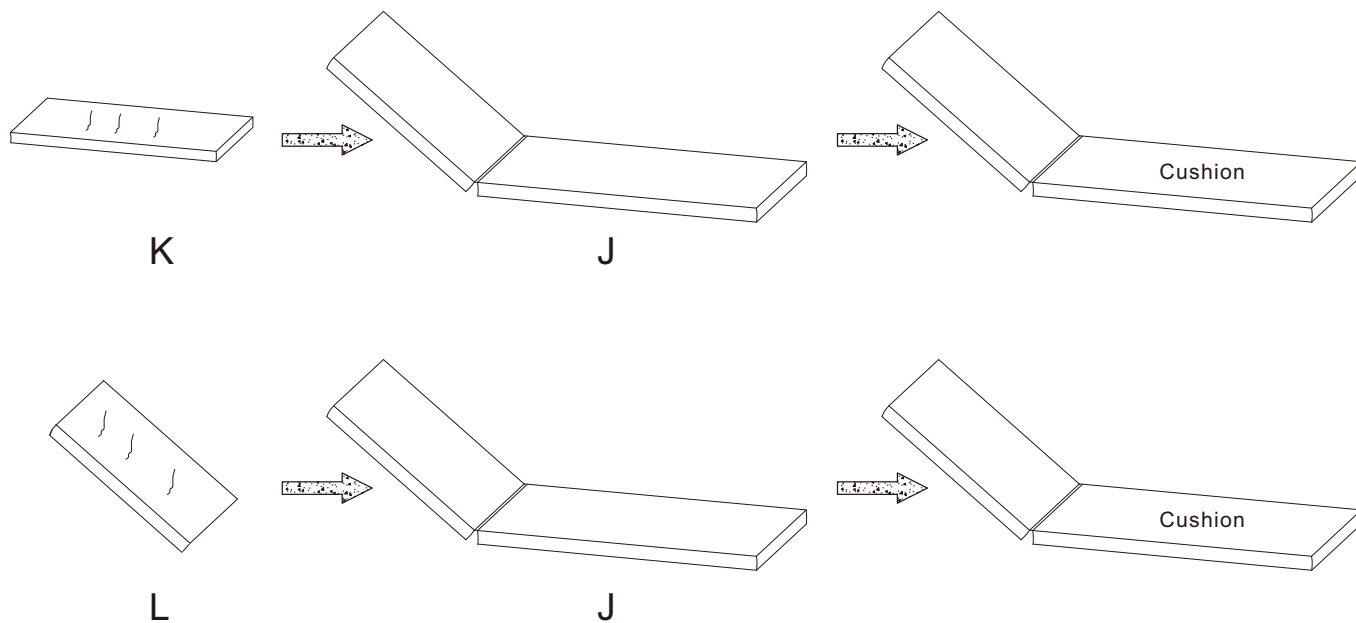

Step 8. Add cushion as shown below.

